

Closed Spelter Sockets

G-417 / S-417

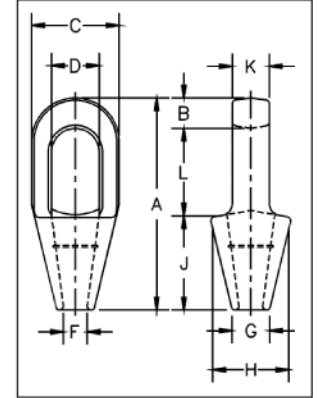

- Forged Steel Sockets thru 1-1/2", cast alloy steel 1-5/8" thru 4".
- Spelter socket terminations have an efficiency rating of 100%, based on the catalog strength of wire rope. Ratings are based on the recommended use with 6 x 7, 6 x 19 or 6 x 37, IPS or XIP (EIP), XXIP (EEIP), RRL, FC or IWRC wire rope.



Closed grooved Sockets meet the performance requirements of Federal Specification RR-S-550D, Type B, except for those provisions required of the contractor. For additional information, see page 391.

NOTICE:

All cast steel sockets 1-5/8" and larger are magnetic particle inspected and ultrasonic inspected. Proof testing available on special order. Drawing illustrates one groove used on sockets 1/4" thru 3/4". Sizes 7/8" thru 1-1/2" use 2 grooves. Sizes 1-5/8" and larger use 3 grooves.

G-417 / S-417 Closed Spelter Sockets

Rope Dia.		Structural Strand Dia. (in.)	Ultimate Load (t)	Stock No.		Weight Each (lbs.)	Dimensions (in.)									
(in.)	(mm)			G-417 Galv.	S-417 S.C.		A	B	C	D*	F	G	H	J	K	L
1/4	6-7	-	4.50	1039897	1039904	.50	4.50	.50	1.50	.88	.38	.69	1.56	2.25	.50	1.75
5/16 - 3/8	8-10	-	12.0	1039913	1039922	.75	4.94	.62	1.69	.97	.50	.81	1.69	2.25	.69	2.06
7/16 - 1/2	11-13	-	20.0	1039931	1039940	1.50	5.50	.69	2.00	1.16	.56	.94	2.00	2.50	.88	2.31
9/16 - 5/8	14-16	1/2	30.8	1039959	1039968	2.50	6.31	.81	2.63	1.41	.69	1.12	2.38	3.00	1.00	2.50
3/4	18	9/16 - 5/8	43.5	1039977	1039986	4.25	7.62	1.06	3.00	1.66	.88	1.25	2.75	3.50	1.25	3.06
7/8	20-22	11/16 - 3/4	65.3	1039995	1040000	7.25	8.75	1.25	3.63	1.94	1.00	1.50	3.25	4.00	1.50	3.50
1	24-26	13/16 - 7/8	81.6	1040019	1040028	10.50	9.88	1.38	4.13	2.30	1.13	1.75	3.75	4.50	1.75	4.00
1-1/8	28-30	15/16 - 1	100	1040037	1040046	14.25	11.00	1.50	4.50	2.56	1.25	2.00	4.13	5.00	2.00	4.50
1-1/4 - 1-3/8	32-35	1-1/16 - 1-1/8	136	1040055	1040064	19.75	12.12	1.63	5.00	2.81	1.50	2.25	4.75	5.50	2.25	5.00
1-1/2	38	1-3/16 - 1-1/4	170	1040073	1040082	29.20	13.94	1.94	5.38	3.19	1.63	2.75	5.25	6.00	2.50	6.00
† 1-5/8	† 40-42	1-5/16 - 1-3/8	188	1040091	1040108	36.00	15.13	2.13	5.75	3.25	1.75	3.00	5.50	6.50	2.75	6.50
† 1-3/4 - 1-7/8	† 44-48	1-7/16 - 1-5/8	268	1040117	1040126	57.25	17.25	2.19	6.75	3.75	2.00	3.13	6.38	7.50	3.00	7.56
† 2 - 2-1/8	† 50-54	1-11/16 - 1-3/4	309	1040135	1040144	79.00	19.87	2.44	7.63	4.38	2.25	3.75	7.38	8.50	3.25	8.81
† 2-1/4 - 2-3/8	† 56-60	1-13/16 - 1-7/8	360	1040153	1040162	105.00	21.50	2.75	8.50	5.00	2.63	4.13	8.25	9.00	3.63	9.75
† 2-1/2 - 2-5/8	† 64-67	1-15/16 - 2-1/8	424	1041759	1041768	140.00	23.50	3.12	9.50	5.50	2.88	4.50	9.25	9.75	4.00	10.62
† 2-3/4 - 2-7/8	† 70-73	2-3/16 - 2-7/16	549	1041777	1041786	220.00	25.38	3.12	10.75	6.25	3.12	4.88	10.19	11.00	4.88	11.25
† 3 - 3-1/8	† 75-80	2-1/2 - 2-5/8	656	1041795	1041802	276.00	27.12	3.37	11.50	6.75	3.38	5.25	11.50	12.00	5.25	11.75
† 3-1/4 - 3-3/8	† 82-86	2-3/4 - 2-7/8	750	1041811	1041820	313.00	29.25	4.00	12.25	7.25	3.62	5.75	12.25	13.00	5.75	12.25
† 3-1/2 - 3-5/8	† 88-92	3 - 3-1/8	820	1041839	1041848	400.00	31.00	4.00	13.00	7.75	3.88	6.31	13.00	14.00	6.25	13.00
† 3-3/4 - 4	† 94 - 102	-	1005	1041857	1041866	542.00	33.25	4.25	14.25	8.50	4.25	7.25	14.25	15.00	7.00	14.00

* Diameter of pin must not exceed pin used on companion 416 socket. Reference adjacent page "D" dimension.

† Cast Alloy Steel.